

# Dodge Ram 2004-2007 System **Installation Guide**



**PROCHARGER**<sup>®</sup>  
SUPERCHARGER SYSTEMS

The **ULTIMATE** Power Adder™

Accessible Technologies, Inc.  
14801 W. 114th Terrace  
Lenexa, KS 66215  
Phone: 913.338.2886  
Fax: 913.338.2879  
techserv@procharger.com

All rights reserved. Accessible Technologies Inc. hereby grants permission to use and reproduce this document for personal use, provided that all copyright information be retained. Reproduction of this document for unauthorized commercial use is strictly prohibited.

Information in this document is subject to change without notice.

ProCharger® is a registered trademark and The Intercooled Supercharging Experts!™ and Designed to Blow Away the Competition™ are trademarks of Accessible Technologies, Inc. and may not be used without express permission.

# INTRODUCTION

Congratulations on purchasing your ProCharger® Dodge Ram 2004-2007 Supercharger System. Read this entire manual before you attempt to install your ProCharger kit. It is imperative that you follow all of the instructions in the order they appear in this installation guide. If you have any questions regarding any aspect of this installation, call us at (913) 338-3086.

## Required Tools and Supplies

- $\frac{3}{8}$ " Socket Set, standard & metric
- Open End Wrench Set, standard & metric
- $\frac{3}{8}$ " Hex Bit Set (allen head), standard & metric
- Flat Screwdrivers
- Phillips Screwdrivers
- Plier Set



**Warning:** Failure to follow the installation instructions completely can result in property damage and/or personal injury.



**Warning:** Read and understand all safety precautions in this manual before installation. Failure to comply with instructions in this manual could result in personal injury, property damage, and/or voiding your warranty.

For best results, review the installation instructions first. Follow the installation instructions closely and in sequence. A detailed packing list has been provided to assist you in identifying the components of your ProCharger system.

For complete system installations, please review the fuel system and tuning section to ensure you have the proper components to complete the installation. Tuning for this vehicle is a multi-step process that can be initialized before the installation has begun. If there are any questions about this process, or any other step during your installation, please call ProCharger Technical Service at 913-338-2886.

# TABLE OF CONTENTS

<b>Introduction .....</b>	<b>i</b>
<b>Removing Stock Components.....</b>	<b>1</b>
<b>Fuel System .....</b>	<b>3</b>
<b>Tuning .....</b>	<b>5</b>
<b>Low Mount Intercooler Installation .....</b>	<b>7</b>
<b>High Mount Intercooler Installation .....</b>	<b>8</b>
<b>ProCharger Installation .....</b>	<b>9</b>
Secondary Bracket Installation.....	9
Main Bracket Installation .....	10
ProCharger Head Unit Installation.....	11
<b>Low Mount Tubing Installation.....</b>	<b>14</b>
<b>High Mount Tubing Installation.....</b>	<b>18</b>
<b>Anti-Surge System Installation .....</b>	<b>22</b>
<b>Air Filter and Intake Cover Installation .....</b>	<b>23</b>
<b>Finishing.....</b>	<b>24</b>
<b>Operation and Maintenance .....</b>	<b>25</b>
<b>Limited Warranty .....</b>	<b>27</b>
<b>ProCharger Extended Coverage.....</b>	<b>28</b>

# REMOVING STOCK COMPONENTS

- 1 Remove the engine intake resonator assembly with a 10mm socket and unplug the sensor underneath.
- 2 Remove the engine air filter assembly and related mountings. Use a 13mm socket to remove the (2) top bolts. Remove (2) 8mm bolts from the passenger side wheel well. Remove the fender lining with an 8mm socket and remove the remaining (2) 13mm bolts.
- 3 Re-install the fender lining.

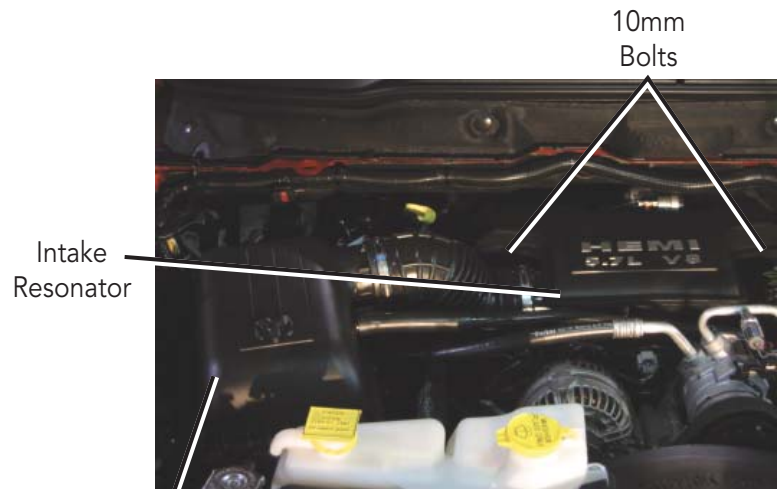

Resonator Assembly

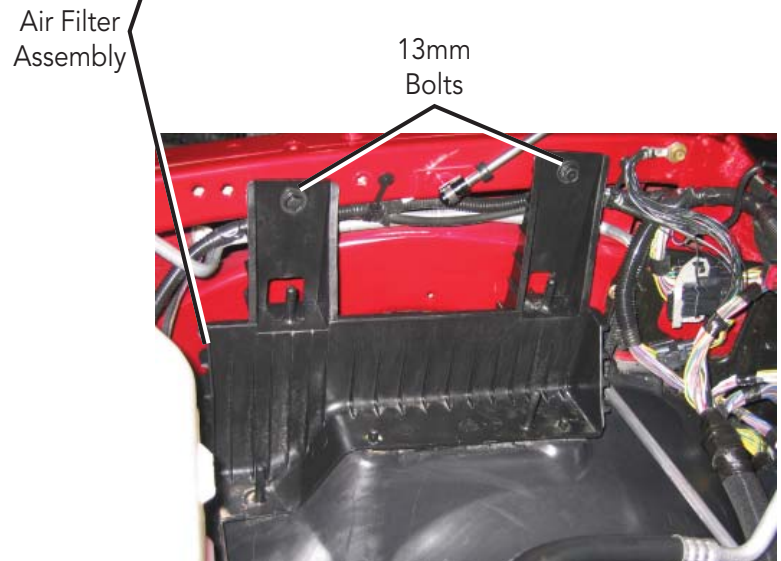

Air Filter Assembly

## Removing Stock Components

- Using a  $\frac{3}{8}$ " socket wrench as a leverage tool, rotate the automatic belt tensioner clockwise to it's stop and remove the engine's 7-rib serpentine belt.

✓ **Tech Tip:** If required, rotate clamps on the two smaller water lines so the clamps do not collide with the ProCharger's main bracket.



Main Water Line Clamps

✓ **Tech Tip:** If required, rotate the main water line clamp, on the lower main radiator hose, so the clamp does not collide with intercooler tubing.

- For the low mount intercooler, remove the bumper insert. The small body panel fasteners must be removed by placing a flat blade screwdriver under the housing and pulling down on the pin. Once all the fasteners are removed the insert can be pulled out from the front side. Replace the body panel fasteners back into the bumper insert holes.



Removing Bumper Insert

! **Warning:** The bumper insert must be completely removed from the truck in order for the intercooler to function properly. Optional partial bumper inserts can be obtained from Dodge.

# FUEL SYSTEM

## Modifying the Fuel System

✓ **Note:** This section only applies to full systems, which include 39.5 lb/hr fuel injectors and a modified 2-bar MAP sensor. If you do not have a full system, additional fuel system components will be required before starting the vehicle.

- 1 Remove the fuel cap.
- 2 Disconnect the battery.
- 3 For 2004-2005 models, remove the #17 fuse. For 2006-2007 models, disconnect the harness located underneath the driver's side fender. This disconnects the fuel pump.
- 4 Reconnect the battery.
- 5 Crank the engine to depressurize the fuel rails.
- 6 Disconnect the battery. Leave the battery disconnected for the remainder of the installation.
- 7 Reconnect the harness located underneath the driver's side fender.
- 8 Unclip the wiring harnesses from each injector. Remove the (4) 10mm bolts securing the fuel rails to the manifold. Pull the fuel rails up off of the manifold to gain access to the fuel injectors.
- 9 Remove the fuel injector retaining clips from the injectors and rails. Remove the injectors by pulling them straight out of the rails.

- 10** Install the new injectors, followed by the factory retaining clips.
- 11** Mount the fuel rail spacers on the manifold, push the injector and rail assembly into place, and tighten the rails with the new hardware. Re-install each wiring harness to each injector.
- 12** Remove the factory MAP sensor located on the top front of the intake manifold. Remove the electrical harness by sliding the red retaining tab back and disconnecting it from the sensor. Remove the 8mm bolt and pull the factory map sensor out of the vehicle.
- 13** Install the new 2-bar MAP sensor, tighten the 8mm bolt, and connect the harness to the new sensor.



Fuel Rail Spacers Installed



2-Bar MAP Sensor Installed

# TUNING

## Hardware and Software Requirements:

### 1. DS Downloader version 1.9.9.6

<http://www.diablosport.com/index.php?module=htmlpages&func=display&pid=121>

### 2. PC or Laptop with internet connection and 9-pin serial port or USB port

A serial cable and an AC to DC power adapter must be obtained. Diablosport offers both of these items in a package that can be purchased through any authorized Diablosport dealer. The part number for this item is U7777. Alternatively, these items can be purchased locally from any Radio Shack or similar electronics retailer. The descriptions, part numbers and recommended source for these items are presented below.



#### 1) Serial Cable

- For PC's with DB-9 serial communications port(s):

A standard, RS-232C, straight through, DB-9 male to DB-9 female cable is required to connect the PC to the Predator.

Recommended Source: Radio Shack part number: 26-117, 6-ft DB9 male to DB9 female shielded RS-232C cable

- For PC's with USB ports only:

If the PC only has USB ports available, a USB to RS-232C converter cable is required. This cable will convert a USB port to a serial port to connect to the Predator.

Recommended Source: Radio Shack part number: 26-183, 6-ft USB to Serial Port Adapter Cable

#### 2) Power Adapter:

The Predator requires a 12 Volt, 1 Amp power source to turn it on. An AC to DC power adapter allows the Predator to be turned on when not connected to the vehicle. The Power Adapter's plug tip is 2.5mm in diameter and 3.5mm in length. The required polarity is center contact is positive and the outer contact is ground.

Recommended Source: Radio Shack part number: 273-1776, 12V/1000mA AC to DC Power Adapter (This item includes a Plug Adapter. Please specify part number: 273-1717 to obtain the correct adapter.

\* Note: If the update will be performed with a laptop computer, the vehicle's OBDII port can be used to substitute for the Power Adapter.



**Note:** This section only applies to full systems, which include a Predator tuner. If you do not have a full system, additional tuning will be required before starting the vehicle.

- 1 Perform the "Calibration Update" using the supplied Predator U7137. Plug the Predator into the vehicle's OBDII port. Proceed to performance tune and follow the on-screen prompts. If no calibration update is prompted, proceed to step 2.
- 2 Install the performance tune, modify stock tune from Predator ECM.
  - 1) Select Performance Tune
  - 2) Select Diablo Tunes
  - 3) Select Modify Stock Tune
- 3 Unplug the handheld from the vehicle.
- 4 Using DS Downloader, download the original file from the Predator to a PC, and email the tune to [tuning@Procharger.com](mailto:tuning@Procharger.com) along with the Procharger serial number in the subject line.
- 5 [Tuning@Procharger.com](mailto:Tuning@Procharger.com) will email back the tune for your vehicle. Upload the tune from your PC to the Predator using DS Downloader.
- 6 Load the Procharger tune from the Predator to the ECM.
  - 1) Select Performance Tune
  - 2) Select Custom Tune
  - 3) Select Tune and follow the on-screen prompts

## LOW MOUNT INTERCOOLER

- 1 Remove the (4) bumper nuts using an 18mm socket or wrench.
- 2 From below the vehicle, install the intercooler brackets, re-using the (4) bumper nuts. Do not tighten.

✓ **Note:** *These are not universal brackets. The driver's side bracket is labeled DS and the passenger side is labeled PS.*

- 3 Install the intercooler between the frame rail and bumper with the openings towards the passenger side using the (4)  $\frac{5}{16}$ "-18 x  $\frac{1}{2}$ " bolts. After you have verified the intercooler position, tighten the bumper nuts to 70 ft-lb.

PS  
Label

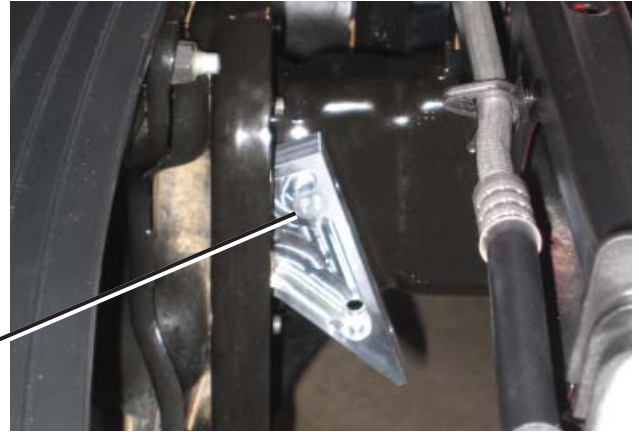

Intercooler Bracket



Intercooler Installed

# HIGH MOUNT INTERCOOLER

- 1 Remove the passenger and driver's side bolts with a 13mm socket
- 2 Install the intercooler brackets with a 6mm hex socket. Leave bolts loose.
- 3 Install the intercooler's top bracket bolts on both the passenger and driver's side and then install the bottom bolts.
- 4 Tighten all bolts.



Removed Driver's Side Bolt



Installed Driver's Side I/C Bracket



Installed Intercooler

# PROCHARGER HEAD UNIT

## Secondary Bracket Installation

- 1 From above the vehicle, install the sub-bracket directly onto the block using the holes above the engine oil filter mount. Start the M8 SHCS using a 6mm hex bit socket. Use thread locking compound. Install the M10 SHCS with an 8mm hex bit socket.

✓ **Tech Tip:** If required, remove a wiring harness tree lock from the top hole.

Mounting  
Holes

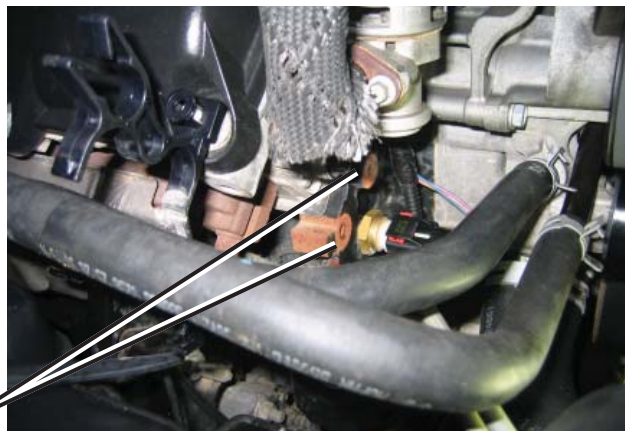

Mounting Holes



Installed Bracket

## Main Bracket Installation

- 1 Using a 15mm socket or wrench, remove the left hex head bolt from the alternator mounting.
- 2 With an 8mm hex bit socket, hang main bracket with M10 SHCS and short spacer in the top hole. Do not tighten.
- 3 With a 6mm hex bit socket, start M8 x 25mm SHCS in the middle hole. Do not tighten.
- 4 With a 6mm hex bit socket, install M8 x 130mm SHCS and long spacer in the bottom hole.
- 5 Go back and tighten all fittings.



Hex Head Bolt

Space for Main Bracket



Main Bracket Installed

## ProCharger Head Unit Installation

**!** **Warning:** The ProCharger® must be filled with oil prior to use. Use only the supplied ATI oil in your supercharger. ATI oil has been specially formulated for the bearings in the supercharger. Use of any other oil will void your warranty.

Foam Strips



ProCharger on the Main Bracket

- 1 Position foam strips according to the photograph. Before mounting the ProCharger, install 3<sup>3</sup>/<sub>4</sub>" diameter hose on the ProCharger intake with a #64 band clamp.
- 2 Place the ProCharger onto the main bracket and screw in all of the 5<sup>1</sup>/<sub>16</sub>" and the 3<sup>3</sup>/<sub>8</sub>" SHCS through the main bracket and into the ProCharger. Once all SHCS are in, go back and tighten all fittings.
- 3 Mount the ProCharger intake tube using the previously installed 3<sup>3</sup>/<sub>4</sub>" hose and a #64 band clamp. Do not install the engine air filter at this time.



Intake Tube

- 4 Disconnect the PCV hose from the housing and trim the hose as shown. Plug it into the side of the intake.

**Warning:** Do not attempt to adjust the idler pulley without loosening the brass lock nut or damage will occur!



Original PCV Hose Length

- 5 Using a  $\frac{1}{4}$ " hex bit, adjust the main bracket's idler pulley to the bottom of the slot. Using a  $\frac{3}{8}$ " socket wrench as a leverage tool, rotate the automatic belt tensioner clockwise to it's stop. Install belt. Tension belt by adjusting the idler pulley up into belt. The automatic belt tensioner neutral mark should be approximately  $\frac{1}{8}$ " from the stop mark. After the belt is tensioned, tighten the brass lock nut with a  $\frac{3}{4}$ " wrench to lock adjustable pulley.



Modified PCV Hose Length

Adjustment



Installed Belt

Belt Routing Diagram

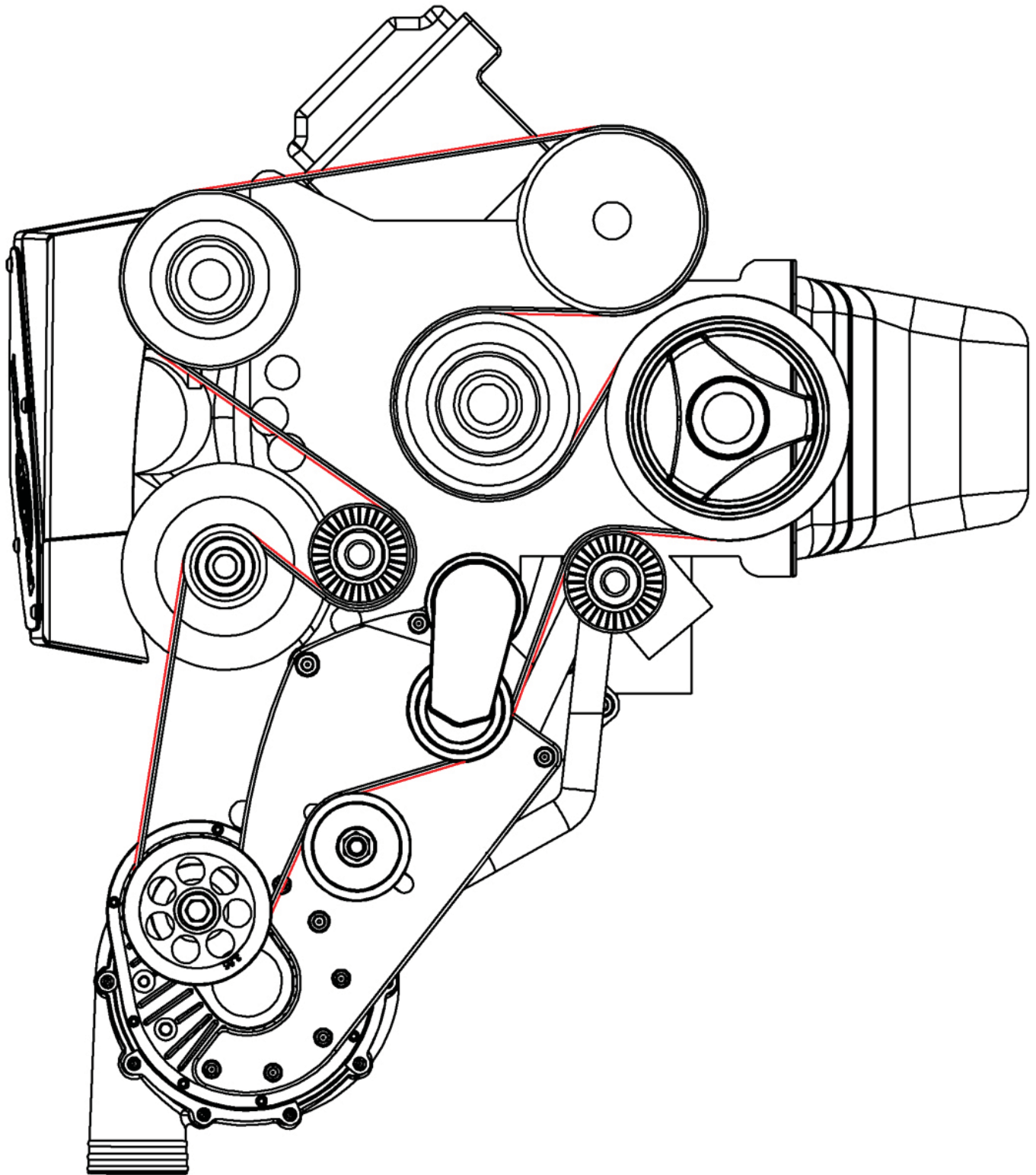

# LOW MOUNT TUBING

Place foam tape between tube AICD1I-015 and the fender.

Place foam tape between tube AICD1I-012 and tube AICD1I-015.

Place foam tape between tube AICD1I-012 and the fender.

Place foam tape between tube AICD1I-011 and tube AICD1I-014.

Place foam tape between tube AICD1I-011 and the fender.

Slide the 3" x 4" rubber hose around tube AICD1I-010 to protect it from the frame and bumper.

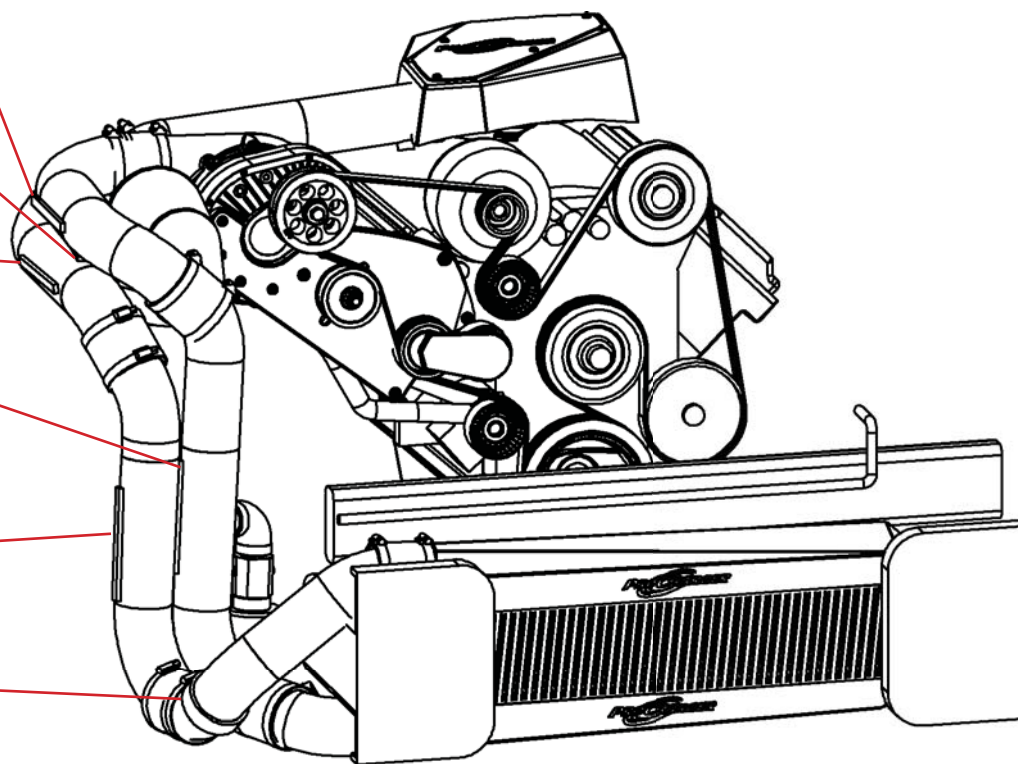

Foam Tape Installation for Vibration Reduction

**Warning:** *Inspect the inside of each tube for any foreign debris. Remove any debris from the interior of the tubes before installing.*

**1** Fasten a 3" x 4" hose to the intercooler's inlet (top tube) with a band clamp. Slide a 3" x 4" section of hose over tube AIDC11-010 to shield the tube from vibrating against the frame or bumper. Slide another band clamp onto the hose and leave loose. From below the vehicle, feed tube AIDC11-010 up through the frame and bumper into the intercooler's hose. Position the tube so it is not touching the frame or bumper and secure with band clamp. Install another coupler and two band clamps.

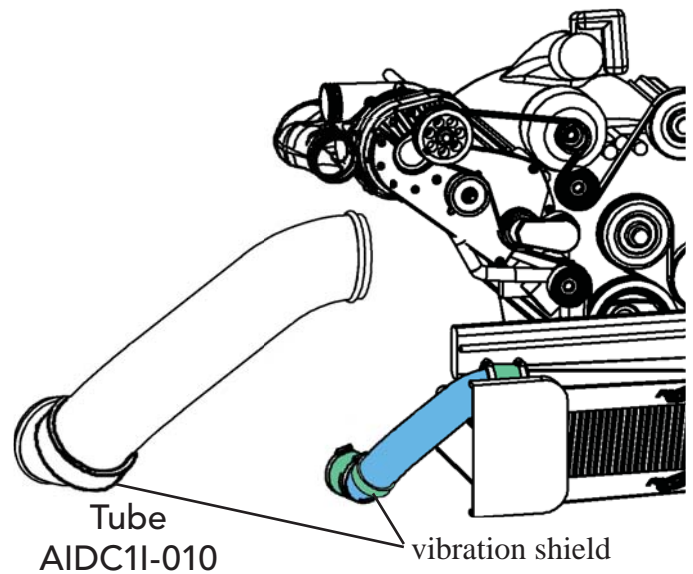

**2** Place foam tape on the tube to shield against vibration from the fender. From below the vehicle, install tube AIDC11-011 into the previously installed hose. On the tube's exposed end, install another hose and two band clamps.

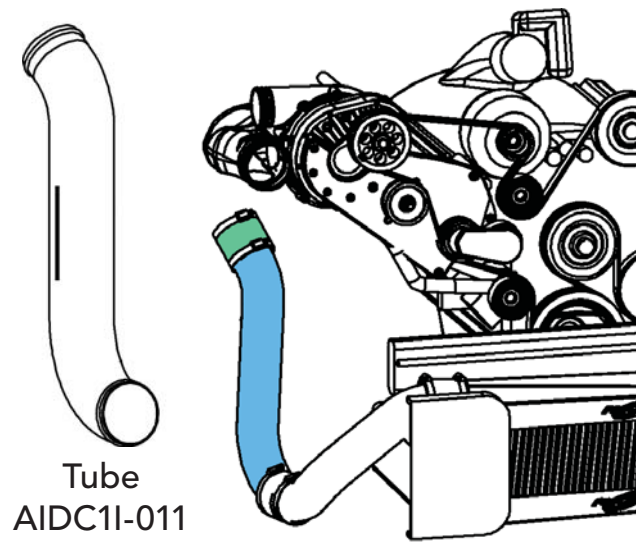

**3** Place foam tape on the tube to reduce the vibration from the fender. Install tube AIDC11-012 into the previously installed hose. Install a 3"x4" hose and two band clamps.

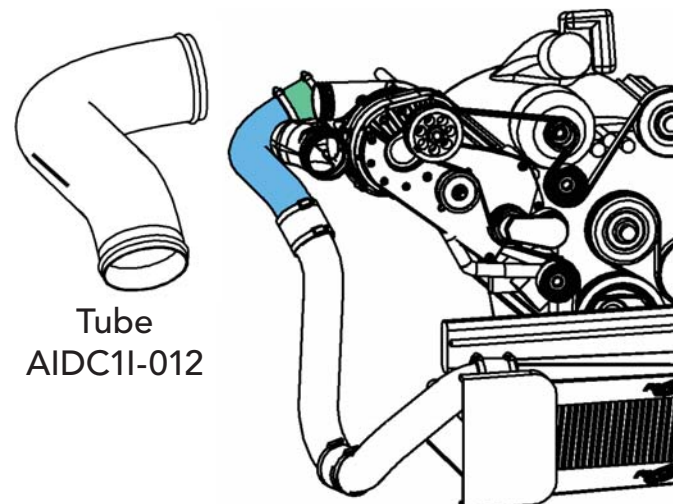

## Low Mount Tubing

4 Trim  $\frac{3}{4}$ " from the  $3\frac{1}{2}$ " diameter side of the rubber reducer. Connect the rubber reducer to the engine intake. Install tube AIDC11-016 into the previously installed hose and the rubber reducer simultaneously. Insert and twist the intake air temperature sensor into the bung on the bottom of tube AIDC11-016. Align all of the tubes and tighten all of the band clamps.

5 Fasten one 3" hose to the intercooler's outlet (bottom tube) with a band clamp. Slide another band clamp onto the hose and leave it loose. Install tube AIDC11-013, from below the vehicle, into the intercooler's hose and secure with a band clamp. Install another hose and two band clamps.

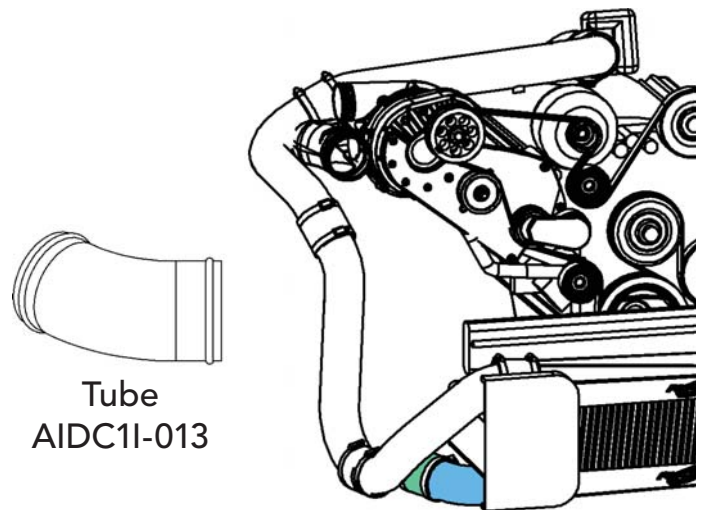
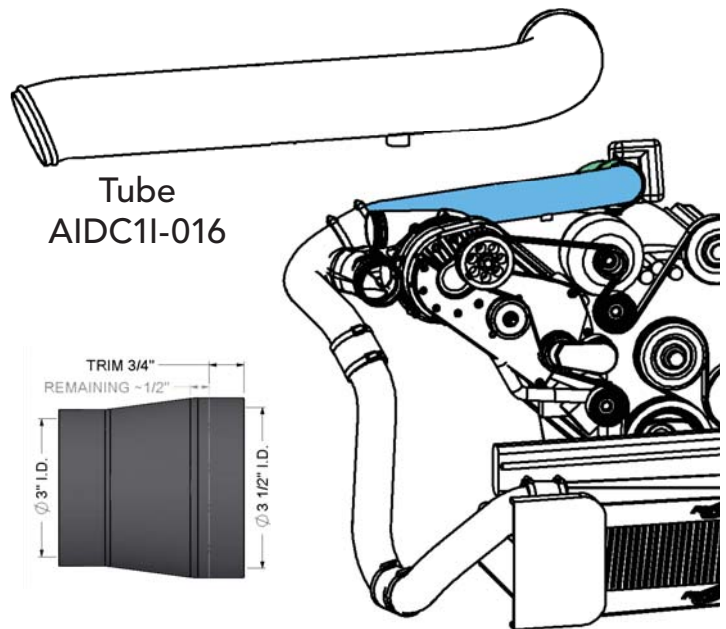

- 6 Place foam tape on the tube to shield against vibration from the fender. Install tube AIDC11-014 into the hose on the end of the previously installed tube. On the exposed end of tube AIDC11-014, install another hose and two band clamps.
  
- 7 Place foam tape on the tube in two places to shield against vibration from the fender and the other tubes. Install the hose and band clamps over the 90° portion of tube AIDC11-015. Push the hose onto the tube until it is flush with the tube end. Install AIDC11-015 into the previously installed hose. Slide hose and band clamps off the 90° portion of the tube and onto the ProCharger discharge. Align all tubes and tighten all band clamps.

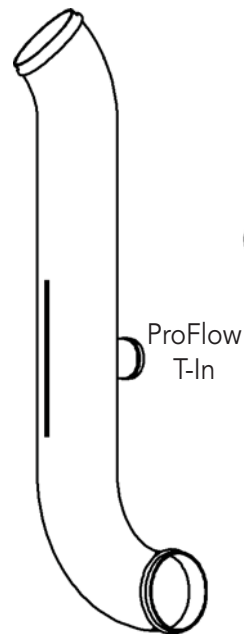

Tube  
AIDC11-014

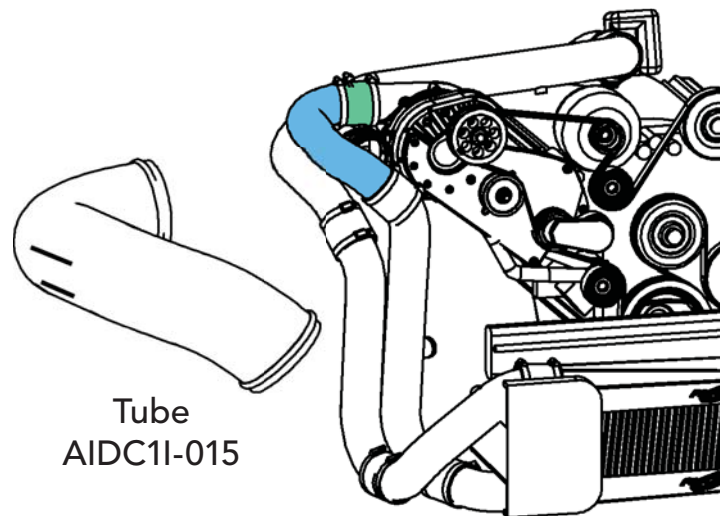
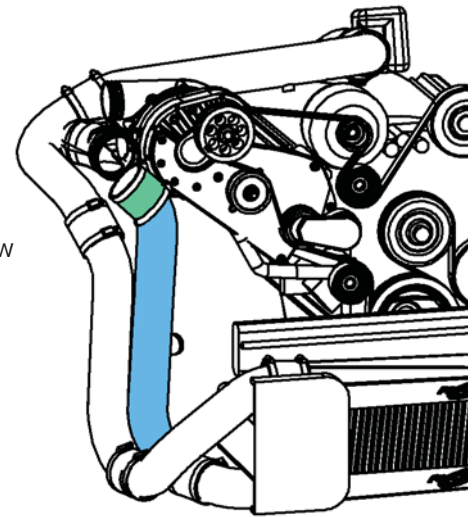

Tube  
AIDC11-015

# HIGH MOUNT TUBING

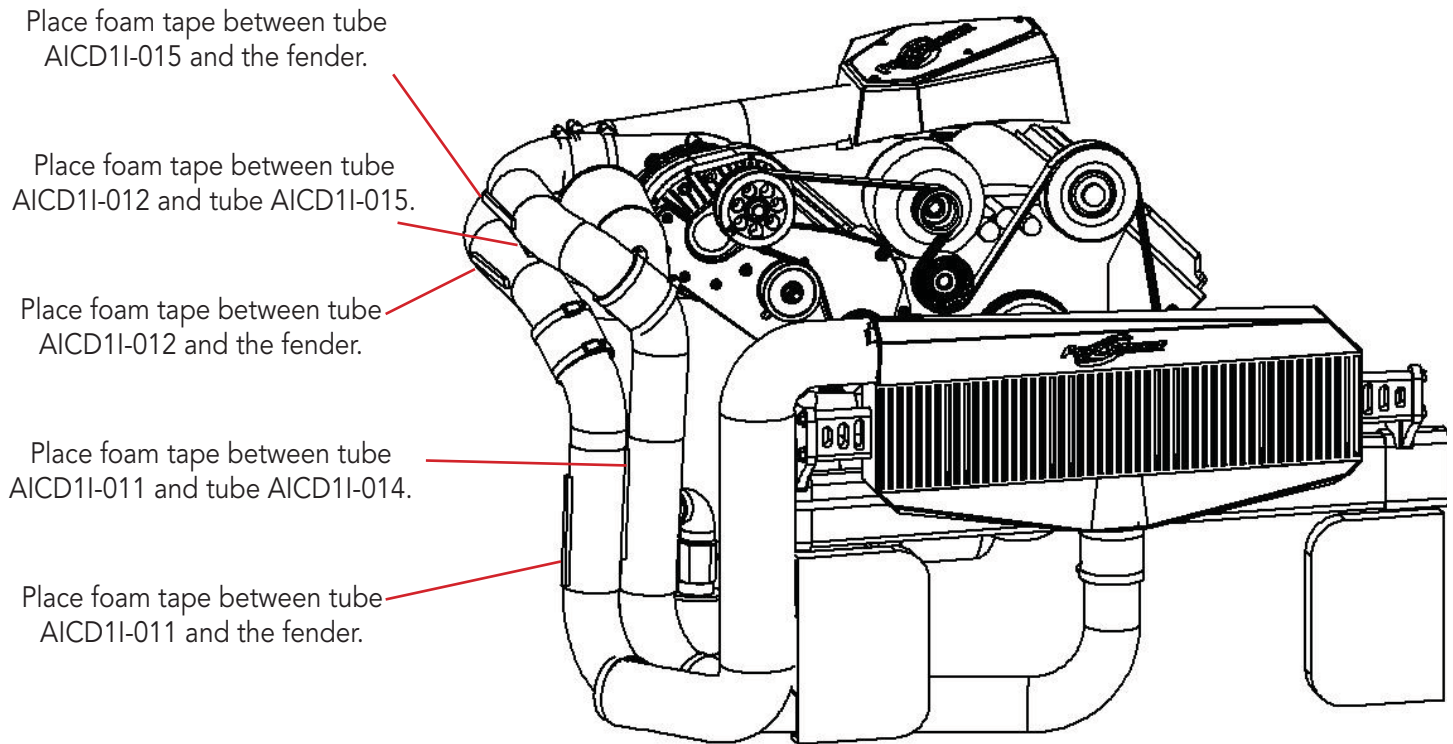

Foam Tape Installation for Vibration Reduction

**!** **Warning:** *Inspect the inside of each tube for any foreign debris. Remove any debris from the interior of the tubes before installing.*

**1** Slide the molded tube MHR12I-011 through the opening beside the intercooler and behind the frame. Secure the tube to the intercooler inlet with a band clamp.

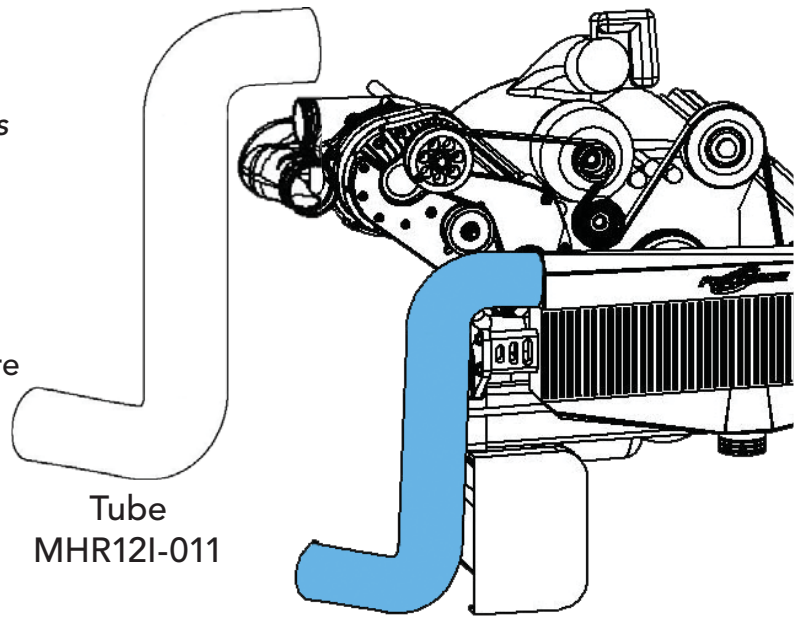

Tube  
MHR12I-011

**2** Place foam tape on the tube to shield against vibration from the fender. From below the vehicle, install tube AIDC1I-011 into the previously installed hose. On the tube's exposed end, install another hose and two band clamps.

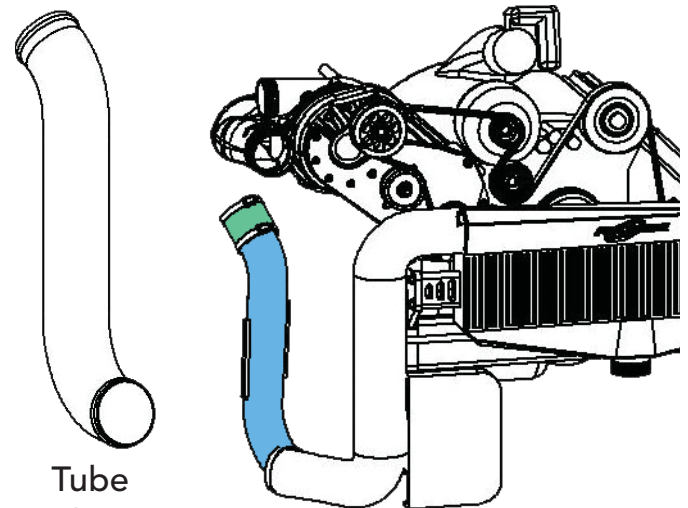

Tube  
AIDC1I-011

**3** Place foam tape on the tube to reduce the vibration from the fender. Install tube AIDC1I-012 into the previously installed hose. Install a 3"x4" hose and two band clamps.

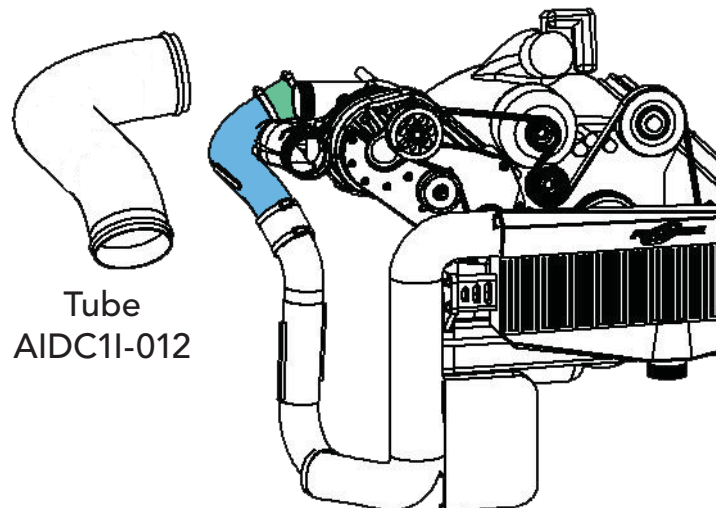

Tube  
AIDC1I-012

- Trim  $\frac{3}{4}$ " from the  $3\frac{1}{2}$ " diameter side of the rubber reducer. Connect the rubber reducer to the engine intake. Install tube AIDC11-016 into the previously installed hose and the rubber reducer simultaneously. Insert and twist the intake air temperature sensor into the bung on the bottom of tube AIDC11-016. Align all of the tubes and tighten all of the band clamps.

- Fasten one 3" hose to the intercooler's outlet (bottom tube) with a band clamp. Slide another band clamp onto the hose and leave it loose. From below the vehicle, install tube AIDC11-017 into the intercooler's outlet hose and secure with a band clamp. Install another hose and two band clamps.

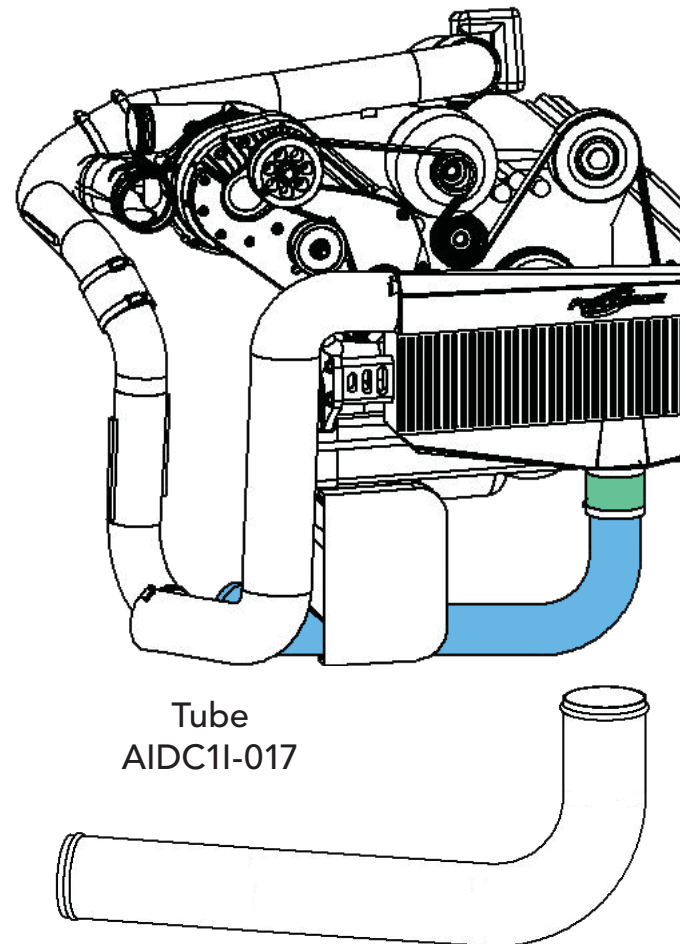
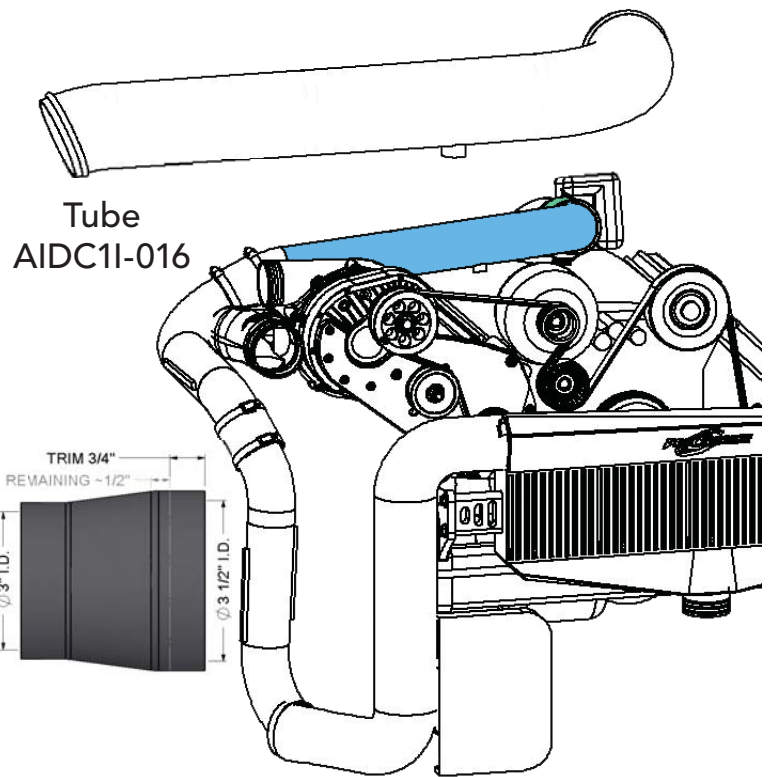

- 6 Place foam tape on the tube to shield against vibration from the fender. Install tube AIDC11-014 into the hose on the end of the previously installed tube. On the exposed end of tube AIDC11-014, install another hose and two band clamps.
- 7 Place foam tape on the tube in two places to shield against vibration from the fender and the other tubes. Install the hose and band clamps over the 90° portion of tube AIDC11-015. Push the hose onto the tube until it is flush with the tube end. Install AIDC11-015 into the previously installed hose. Slide hose and band clamps off the 90° portion of the tube and onto the ProCharger discharge. Align all tubes and tighten all band clamps.

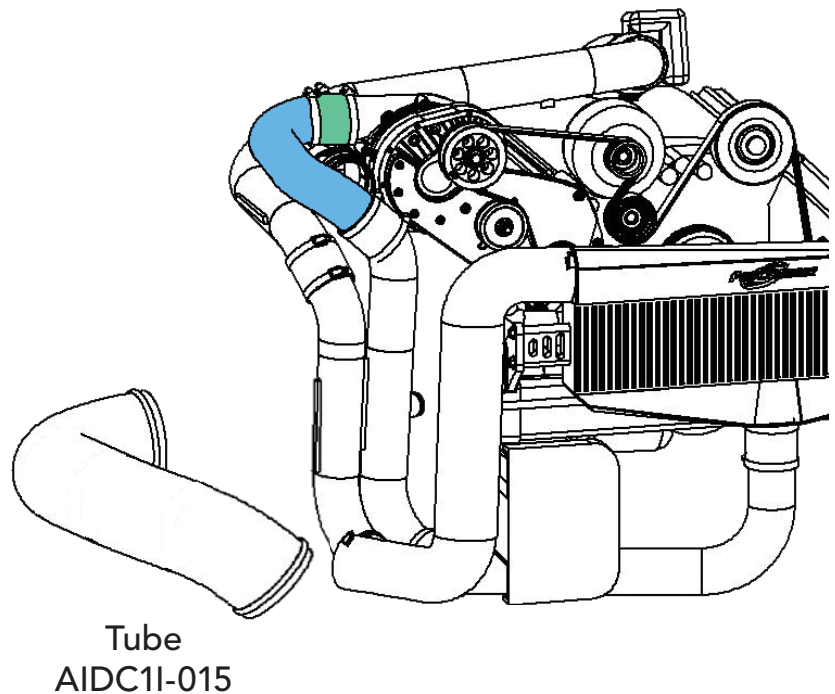
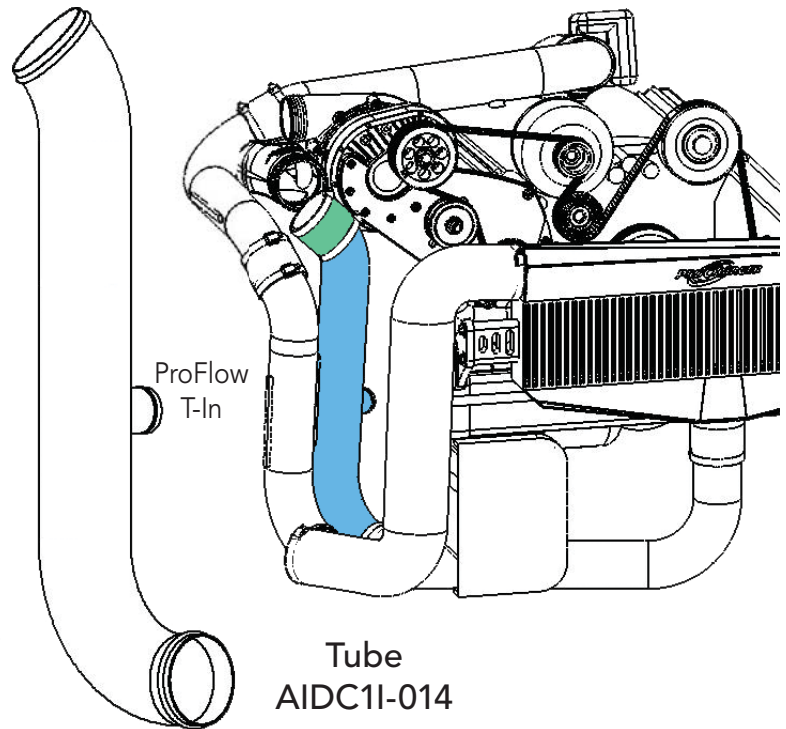

# ANTI-SURGE SYSTEM

- 1 Trim the elbow hose  $\frac{1}{2}$ " on each end.
- 2 Align the hose to the ProFlow as shown. Use two #24 band clamps to install the ProFlow according to the photo.
- 3 Route the vacuum line from the brake booster and connect it to the to the ProFlow.

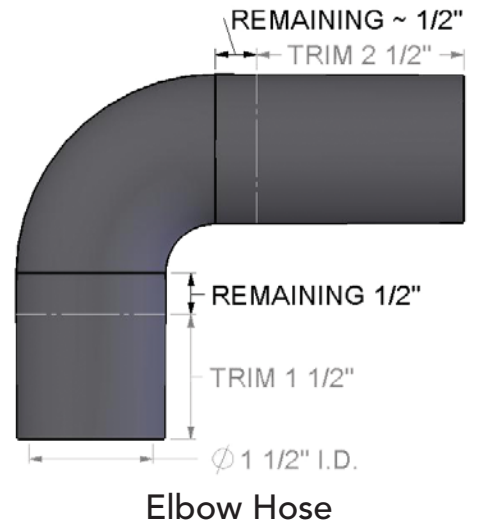

ProFlow Unit

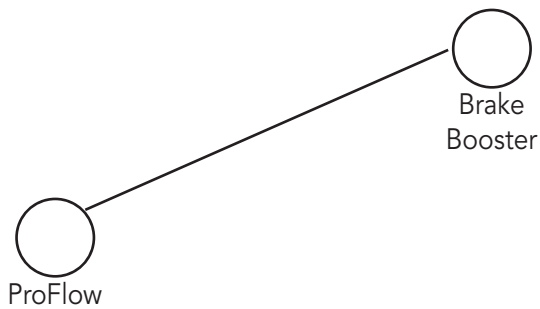

Vacuum Line Route



ProFlow Unit Installed

# AIR FILTER AND INTAKE COVER

- 1 Secure the air filter onto the supercharger intake tube and tighten the band clamp.
- 2 Install the engine intake cover with two #52 band clamps.
- 3 Install the engine intake cover top with (4) 1/4"-20 x 3/4" BHCS screws.



# FINISHING

- 1 Reconnect the battery.
- 2 Check all of the fluid levels.
- 3 Verify you are only using 91 octane or higher fuel.
- 4 Start your vehicle and check for fuel leaks.

# OPERATION AND MAINTENANCE

## Cold Starting

Never race your engine and ProCharger supercharger when your engine is cold. Allow the water temperature to climb into operating range for several minutes before driving above 2,500 rpm, to ensure adequate oil lubrication.

## Fuel Quality

With a properly installed intercooled ProCharger supercharger system, detonation should not occur. For the best performance and reliability, use premium grade fuel (91 octane or higher). Listen for signs of detonation after refueling, and after replacement or modification of any fuel system component(s). If detonation occurs, reduce the throttle and locate the source.

## Ignition System Maintenance

If your spark plugs are more than a year old or have more than 10,000 miles logged, you should consider changing them before driving your vehicle under load. Spark plug wires should be changed if visibly damaged or when resistance exceeds factory specifications.

## Air Filter Maintenance

Your air filters should be cleaned periodically, potentially as often as every 10,000 miles or 6 months, even though a service interval of 50,000 - 100,000 miles is quoted by the manufacturer under normal driving conditions. A clogged air filter will result in decreased boost levels and vehicle performance. Be sure to re-oil the cleaned filter before re-installing. Always operate your vehicle with an air filter, failure to do so may result in damage to your ProCharger supercharger and personal injury!

## Belt Replacement

The serpentine belt, which turns your ProCharger supercharger, will stretch after initial run-in, and should be retightened after the first hundred miles. Tighten the belt sufficiently to avoid slippage, but do not overtighten. Overtightening the belt could cause damage to the ProCharger supercharger's precision bearings. When reinstalling the belt, use the belt routing diagram in this manual. If you reuse a thrown belt and find that it needs frequent re-tightening, the belt is damaged and should be replaced. Gates Micro-V belts can be bought from ATI or from your local parts store.

## ProCharger Oil Change Intervals

The first oil change should be performed at 500 miles and at 6,000 mile intervals thereafter. Clean drain plug after every oil change. Drain oil by removing the drain plug. Clean off drain plug before reinstalling.

## ProCharger Oil Level

The ProCharger supercharger's oil level must be checked periodically to ensure the proper lubrication. The dipstick can be loosened using a flat blade screwdriver or a coin. When installed, the oil level should remain between the minimum (MIN) and maximum (MAX) indicators at all times.

**!** **Warning:** Filling the ProCharger higher than the maximum level on the dipstick can lead to bearing and seal damage. The supercharger is a sealed unit and should not normally require the addition of oil between service intervals. If excessive usage is noted, the unit should be sent to ATI for inspection and repair. The dipstick fitting should be firmly tightened after changing or checking the oil level.

## General

When removing the warning tag from the dipstick, be sure to retain the nylon washer. A spare nylon washer and o-ring is included. Use only the ATI supplied nylon washer and o-ring when servicing the oil dipstick and drain plug. A discoloration of the oil and residue on the drain plug may occur during the initial oil changes. This is normal and will gradually decrease. For the proper positioning of the ProCharger supercharger, the serial tag should be pointing upwards. Installing the ProCharger supercharger in another position will cause inadequate oiling and supercharger failure. If you have any questions about the maintenance of your supercharger, contact ATI.

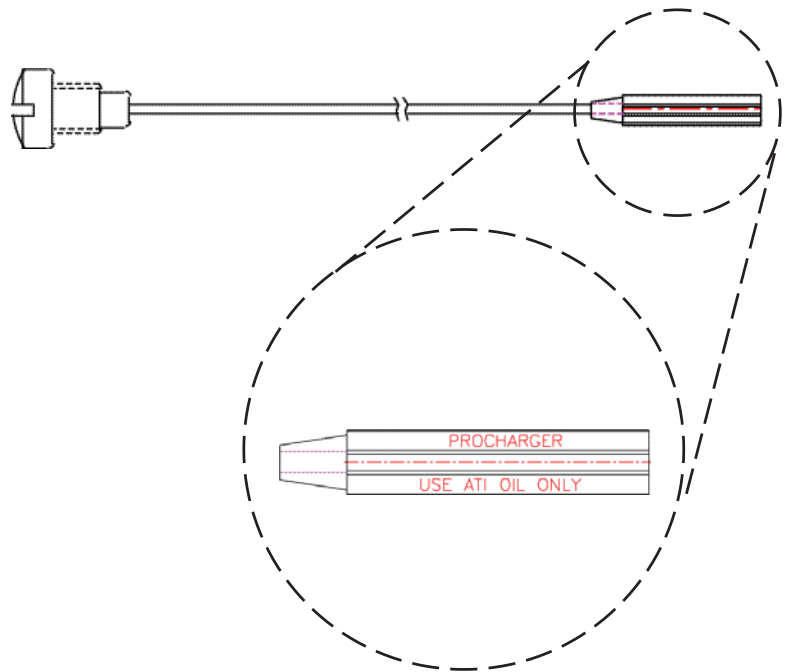
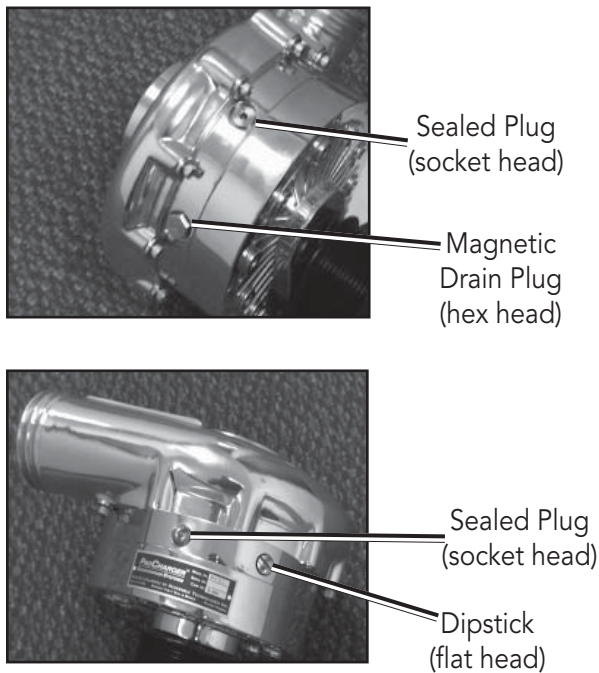

## LIMITED WARRANTY

Accessible Technologies, Inc. (ATI) provides a limited twelve (12) month warranty on the ProCharger supercharger against defects in materials and workmanship unless otherwise specified. This limited warranty starts on the date of original purchase from your local dealer, or date of shipment from the factory. This limited warranty coverage is extended only to the original owner and excludes hoses, sleeves, and electronic components manufactured by other companies. IF THE SUPERCHARGER'S DRIVE RATIO IS ALTERED IN ANY WAY FROM THE FACTORY SETTING, WARRANTY COVERAGE IS VOID. USE OF ANY PULLEY NOT MANUFACTURED OR SUPPLIED BY ATI VOIDS ALL WARRANTY COVERAGE.

ATI's warranty obligations are limited to the terms below:

ATI agrees to honor a warranty claim at its sole discretion and only after inspection at the ATI factory. No warranty will be honored if any part of the product is found to have been improperly installed, tampered with, mishandled, or misused in any way. Disassembly of the ProCharger supercharger or removal of the ProCharger supercharger's serial plate voids all warranties. Claims for freight damages should be directed to the freight company.

If ATI's limited warranty applies, your product will be repaired or replaced at ATI's discretion and shipped back. If the limited warranty does not apply, ATI will advise you of the specific reason, cost of the repair, and delivery time. After advising you of this information we will, at your option, either proceed with repairs or return your product to you in the state in which it was received. In either case the product will be shipped to you, insured at replacement value. Therefore, you will pay the return shipping and insurance charges if ATI's limited warranty does not apply to your product.

THE WARRANTY AND REMEDIES SET FORTH ABOVE ARE EXCLUSIVE AND IN LIEU OF ALL OTHERS, ORAL OR WRITTEN, EXPRESS OR IMPLIED. THE DURATION OF ANY AND ALL WARRANTIES ON THE PRODUCTS DISCUSSED ARE LIMITED TO THE PERIOD IDENTIFIED ABOVE. ATI IS NOT RESPONSIBLE IN ANY EVENT FOR DIRECT, SPECIAL, INCIDENTAL OR CONSEQUENTIAL DAMAGES. No ATI dealer, agent, or employee is authorized to make any modification, extension, or addition to this warranty.

To obtain service under this warranty you must do the following during the warranty period:

Phone ATI (913-338-3086) and provide us with the following information:

- ProCharger supercharger serial number.
- Vehicle year, make, model, engine modifications, and other modifications.
- Description of perceived issue.

If a solution to your issue can not be found after the above phone consultation, you will be assigned a return authorization number (RMA). Package the You must then properly ship your product, at your expense, to the ATI factory. The product should be carefully packaged in a rugged box.

**Include the following information inside the box with your product:**

- Copy of your original invoice or receipt.
- Name, address, and daytime telephone number.
- Return authorization number (RMA).
- Vehicle year, make, model, engine modifications, and other modifications.
- Description of perceived issue.

Clearly mark the warranty claim number on the top and one side of the box in characters at least 2" tall. Properly package the product and ship it, prepaid and insured for the retail value of the component(s) being returned, to the following address:

**Accessible Technologies, 14801 West 114th Terrace,  
Lenexa, Kansas 66215**

# PROCHARGER EXTENDED COVERAGE

The ProCharger Extended Coverage Program extends the ProCharger warranty coverage for your an additional twenty-four (24) months, for a total of thirty-six (36) months or three years of coverage. This extended coverage applies to parts for the ProCharger supercharger head unit only and does not include other system components. With your extended coverage registration, you will receive two (2) additional boxes of ProCharger Supercharger oil.

Under the extended coverage program, Accessible Technologies, Inc. (ATI) will repair or replace any component within the supercharger head unit which is found to be defective. Only the supercharger head unit itself is included in the extended coverage.

Service under the extended coverage program is obtained through the same process as described in the Limited Warranty.

Race kits and tuner kits are not eligible for the ProCharger Extended Coverage Plan

### To qualify for the ProCharger Extended Coverage:

- Only the original owner of the ProCharger supercharger is eligible.
- Completion of the Extended Coverage Registration Form is required, along with a \$49 registration fee. This form must be completed in its entirety, and must be submitted along with payment within 30 days from the date of original purchase from your local dealer or date of shipment from the factory.
- Participants must have a ProCharger P-1SC, P-1SC-1, C1, or C2 supercharger head unit using the maximum warranted boost level. All terms and conditions within "The Limited Warranty" apply. Acts resulting in disqualification include but are not limited to the following:
  - Disassembly or modification the ProCharger supercharger.
  - Removal or attempted removal of the ProCharger drive pulley(s).
  - Removal or attempted removal of the ProCharger supercharger serial number plate.
  - Removal or attempted removal of the compressor housing or transmission case.
- Participants agree to properly maintain the ProCharger supercharger and provide proof of compliance with the following recommended maintenance:
  - Change the ProCharger supercharger oil after the initial break-in period of 500 miles (automotive) or 15 hours (marine).
  - Change the ProCharger supercharger oil every 6,000 miles after the initial break-in period.
  - Use only the specified amount of ProCharger Supercharger oil in the ProCharger supercharger.
  - Inspect and clean the magnetic drain plug at every ProCharger supercharger oil change.
  - Check the ProCharger supercharger oil level frequently.

# ProCharger Extended Coverage Program Registration Form

Return this completed form and a \$49 check within 30 days of original purchase.

Name: \_\_\_\_\_

Date of Purchase: \_\_\_\_\_

Address: \_\_\_\_\_

Purchased From: \_\_\_\_\_

City: \_\_\_\_\_

ProCharger Serial #: \_\_\_\_\_

State: \_\_\_\_\_ Zip: \_\_\_\_\_

Vehicle Year: \_\_\_\_\_

Daytime phone: \_\_\_\_\_

Vehicle Make: \_\_\_\_\_

Evening phone: \_\_\_\_\_

Vehicle Model: \_\_\_\_\_

E-mail: \_\_\_\_\_

Please rank in order of importance starting with 1 being most important.

Age  18 - 24  25 - 34  35 - 44  
 45 - 54  55 and up

Which information sources most influenced your decision to purchase a ProCharger system?

Income  \$15,000 - \$29,000  \$30,000 - \$44,000  
 \$45,000 - \$69,000  \$70,000 and up

- \_\_\_ Magazine advertising
- \_\_\_ Dealer recommendation
- \_\_\_ ProCharger Brochures
- \_\_\_ Witnessed performance on a car
- \_\_\_ Test drive
- \_\_\_ Magazine editorials
- \_\_\_ Friends
- \_\_\_ Conversations with ATI technicians
- \_\_\_ Web Site (please specify) \_\_\_\_\_
- \_\_\_ Other (please specify) \_\_\_\_\_

What magazines do you read?

- Car & Driver
- Car Craft
- Chevy High Performance
- Four Wheel and Off Road
- Hot Rod
- Motor Trend
- Muscle Mustangs and Fast Fords
- GM High-Tech Performance
- 5.0 Mustang
- Super Street
- Mustang Monthly
- Truck Trends
- Popular Hot Rodding
- Road & Track
- Sport Truck
- Super Chevy
- Truckin'
- Sport Compact Car
- Street Truck

What most influenced your decision to purchase a ProCharger system?

- \_\_\_ Reliability
- \_\_\_ Standard warranty
- \_\_\_ Extended coverage warranty
- \_\_\_ Performance
- \_\_\_ Quiet operation
- \_\_\_ Removability (ability to return car to stock)
- \_\_\_ Cost
- \_\_\_ Ease of Installation

Who installed your ProCharger system?  Self  Dealer  Other \_\_\_\_\_

Have you own a forced induction system previously?  Yes  No

If yes:

Supercharger: Brand(s) \_\_\_\_\_ Vehicle(s) \_\_\_\_\_

Turbocharger: Brand(s) \_\_\_\_\_ Vehicle(s) \_\_\_\_\_

I have read and understand the policy for the ProCharger Extended Coverage Program. I have not and will not modify my ProCharger supercharger in any way during my participation in the extended coverage program. I have read and answered all questions on this form. I have enclosed my check for \$49, payable to ATI, for enrolling my ProCharger supercharger (serial number indicated above) in the extended coverage program for an additional twenty-four (24) months beyond the standard limited warranty period of twelve (12) months.

Signature \_\_\_\_\_ Date \_\_\_\_\_

Mail this completed registration form with a \$49 check to ATI at: 14801 West 114th Terrace, Lenexa, KS 66215. If you have any questions, contact us at techserv@procharger.com or (913) 338-2886 8:30 AM - 5:30 PM CST, Monday - Friday.

cut along the dotted line

cut along the dotted line

This Page is Intentionally Left Blank

This Page is Intentionally Left Blank



**Accessible Technologies, Inc.**  
**14801 W. 114th Terrace**  
**Lenexa, KS 66215**  
**Phone: 913.338.2886**  
**Fax: 913.338.2879**  
**techserv@procharger.com**

**Accessible Technologies, Inc.**  
**©2007 ATI, All Rights Reserved**  
**Part Number PMDC1A-001 Rev. E**